

SECTION A-A

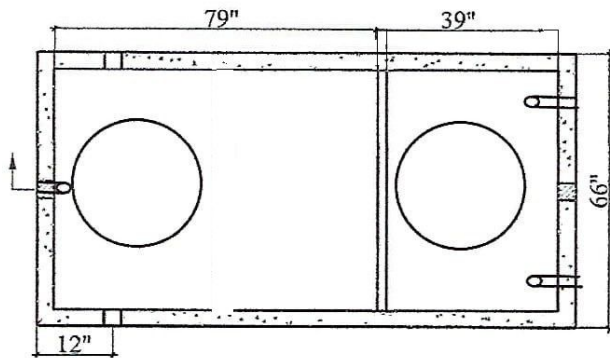

PLAN VIEW

**NOTES:**

1. CONCRETE STRENGTH = MIN. 4500 PSI
2. STRUCTURAL FIBER REINFORCEMENT
3. "POLYLOK" PIPE SEALS CAST IN TANK
4. MASTIC SEALANT IN TANK JOINT
5. 3" WALL THICKNESS
6. 24" Diameter Polylok Riser/Lid
7. 1-1/2" Galvanized Threaded Pipe (2 Inlet, 1 Outlet)

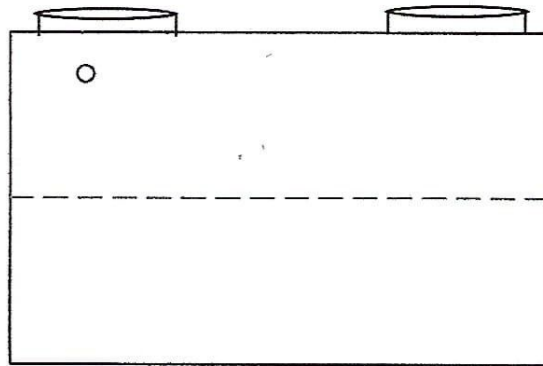

FRONT VIEW

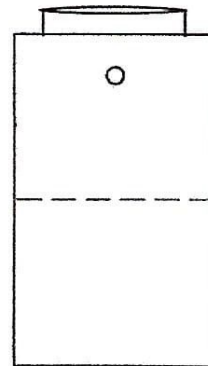

SIDE VIEW

**APPROX. WEIGHT:**

TOP = 5640 lb  
 BOTTOM = 5640 lb  
 TOTAL = 11280 lb

GAL. PER IN = 32  
 ACTUAL GAL. TO OUTLET = 1742  
 FULL CAPACITY = 1838

**LAKESIDE PRECAST**

ABINGDON, VIRGINIA  
 PH: 276-628-2472

**1500 Gal. MS Tank 2 Comp**

Date  
 July 30, 2020

Scale  
 Not To Scale

Sheet  
 1